



VELJAN

Service Information

SS4 - 00107

VT6ED - VT6EDM - VT6EDP

Double vane pump

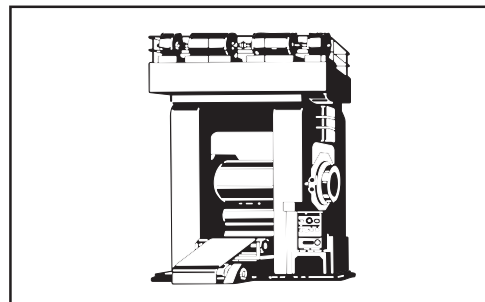
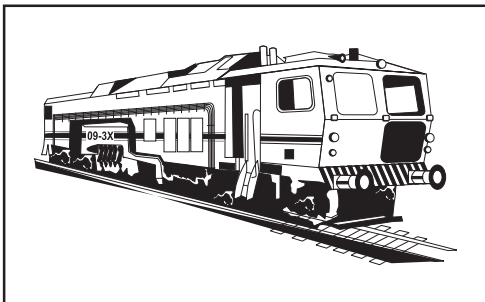
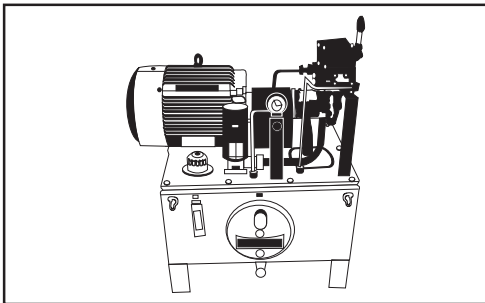
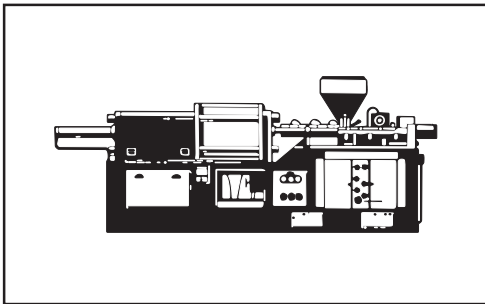

Bold printed are recommended repair kits and assemblies

Mounting torque		4	5
Item pos.		138	138
ft-lbs		187	187
N-m		187	187

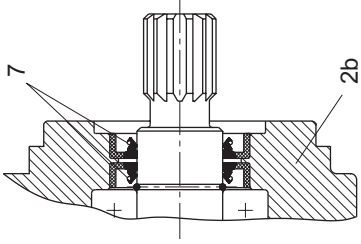

VT6EDP

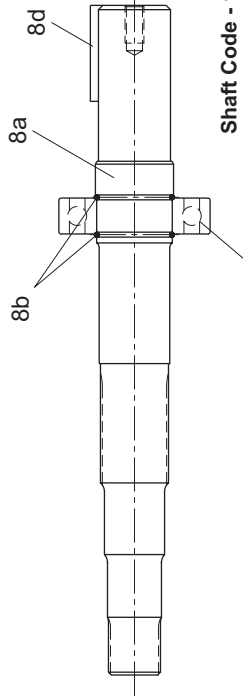
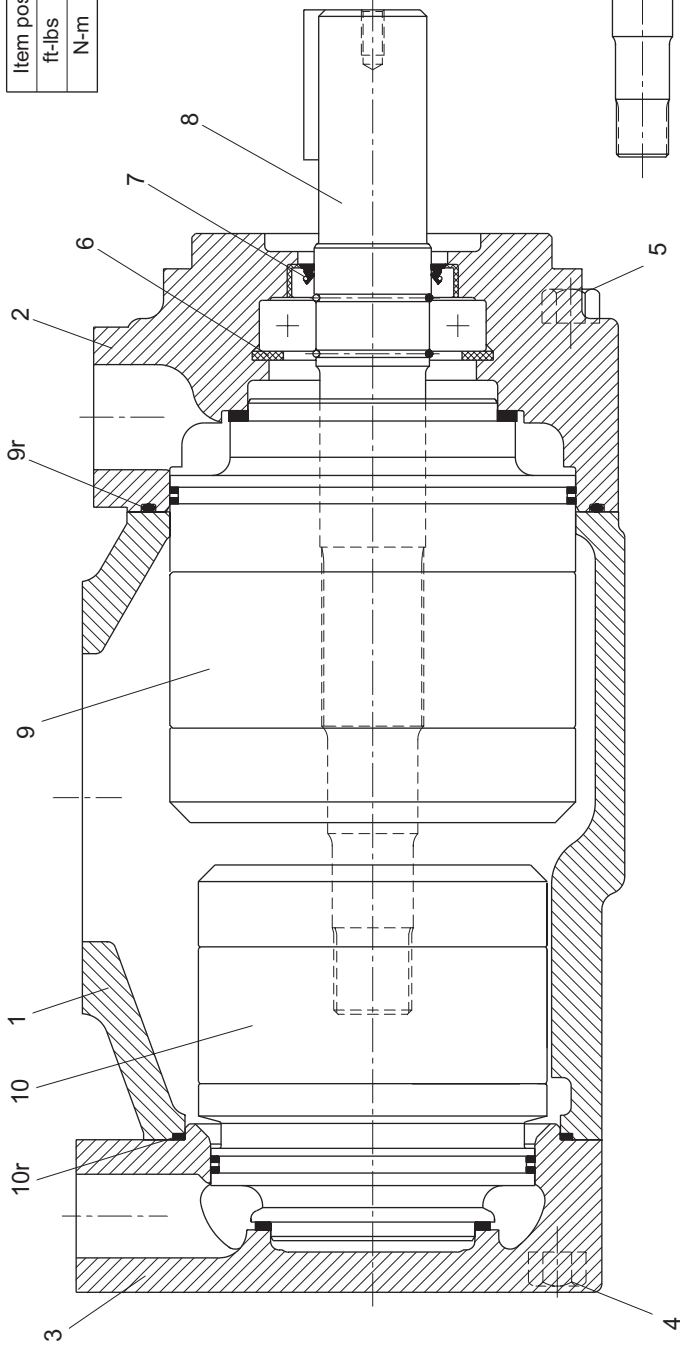

ITEM 9r
INCLUDED

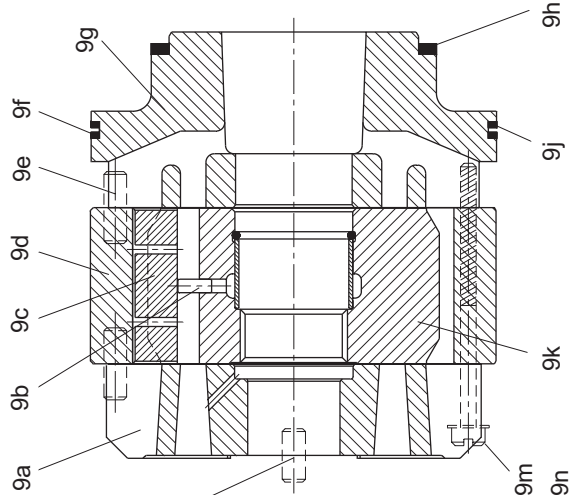

ITEM 10r
INCLUDED

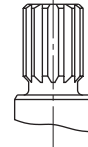
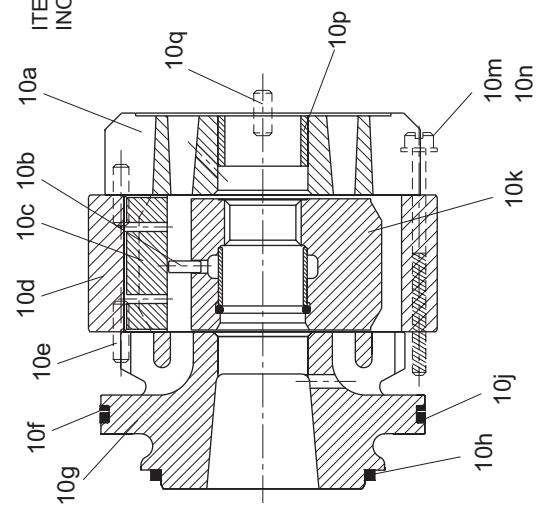

Shaft Code - 2

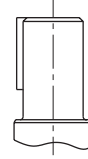

Shaft Code - 3

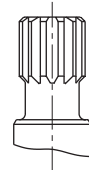

Shaft Code - 4

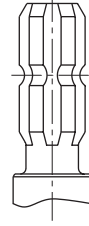

Shaft Code - T

Item pos.	Description	Part No.			Qty
		VT6ED (Standard)	VT6ED (Bi-dir plates) (only for P2)	VT6EDM/VT6EDP -0**-B**	
1	Housing (UNC)	V034-70271	V034-70271	V034-70271	1
	Housing (Metric)	C-034-03072	C-034-03072	C-034-03072	
2	Mounting flange (UNC)	V034-70265	V034-70265	V034-70265	1
	Mounting flange (Metric)	C-034-03070	C-034-03070	C-034-03070	
	Mounting flange (UNC) (VT6EDP)			V034-66746	
	Mounting flange (Metric) (VT6EDP)			C-034-03071	
3	End cap (UNC)	V034-70275	V034-70275	V034-70275	1
	End cap (Metric)	C-034-03073	C-034-03073	C-034-03073	
4	Mounting Screw	V306-40156	V306-40156	V306-40156	4
5	Mounting Screw	V306-40216	V306-40216	V306-40216	4
6	Retaining ring	V356-30315	V356-30315	V356-30315	1
7	Shaft seal (S1-0.7 bar)	V620-82064	V620-82064	V620-82064	1
	Shaft seal (S4-S5-7 bar)	V620-82072	V620-82072	V620-82072	
	Shaft seal (S1-0.7 bar) (VT6EDP)			V620-82064	
					2
8	Shaft and bearing ass'y (#1)	VS14-28182	VS14-28182	VS14-28182	1
	Shaft and bearing ass'y (#2)	VS14-49214	VS14-49214	VS14-49214	
	Shaft and bearing ass'y (#3)	VS14-28180	VS14-28180	VS14-28180	
	Shaft and bearing ass'y (#4)	VS14-28181	VS14-28181	VS14-28181	
	Shaft and bearing ass'y (#T)			VS24-40543	
	Shaft and bearing ass'y (#3) (VT6EDP)			VS24-40349	
8a	Shaft (Keyed) (Code-1)	V034-71416	V034-71416	V034-71416	1
	Shaft (Keyed) (Code-2)	V034-66892	V034-66892	V034-66892	
	Shaft (Splined) (Code-3)	V034-71415	V034-71415	V034-71415	
	Shaft (splined) (Code-4)	V034-71417	V034-71417	V034-71417	
	Shaft (Splined) (Code-T)			V034-66732	
	Shaft (Splined) (Code-3) (VT6EDP)			V034-66754	
8b	Round section ring	V034-70866	V034-70866	V034-70866	2
8c	Ball bearing	V230-03208	V230-03208	V230-03208	1
8d	Key (Code -1)	V034-70330	V034-70330	V034-70330	1
	Key (Code -2)	V034-49676	V034-49676	V034-49676	
9	Cartridge assembly 042 C.W. (P1)	VS24-43930	VS24-43930	C-S14-71659	1
	Cartridge assembly 042 C.C.W. (P1)	VS24-43931	VS24-43931	C-S14-71660	
	Cartridge assembly 045 C.W. (P1)	VS24-10205	VS24-10205	VS24-40377	
	Cartridge assembly 045 C.C.W. (P1)	VS24-10206	VS24-10206	VS24-40378	
	Cartridge assembly 050 C.W. (P1)	VS24-40769	VS24-40769	VS24-40771	
	Cartridge assembly 050 C.C.W. (P1)	VS24-40770	VS24-40770	VS24-40772	
	Cartridge assembly 052 C.W. (P1)	VS24-10207	VS24-10207	VS24-40379	
	Cartridge assembly 052 C.C.W. (P1)	VS24-10208	VS24-10208	VS24-40380	
	Cartridge assembly 062 C.W. (P1)	VS24-10209	VS24-10209	VS24-40381	
	Cartridge assembly 062 C.C.W. (P1)	VS24-10210	VS24-10210	VS24-40382	
	Cartridge assembly 066 C.W. (P1)	VS24-10211	VS24-10211	VS24-40383	
	Cartridge assembly 066 C.C.W. (P1)	VS24-10212	VS24-10212	VS24-40384	
	Cartridge assembly 072 C.W. (P1)	VS24-40375	VS24-40375	VS24-40385	
	Cartridge assembly 072 C.C.W. (P1)	VS24-40376	VS24-40376	VS24-40386	
	Cartridge assembly 085 C.W. (P1)	VS24-59352	VS24-59352	C-S14-71663	
Cartridge assembly 085 C.C.W. (P1)	VS24-68983	VS24-68983	C-S14-71664		
9a	Port plate - rear C.W.	V034-59082	V034-59082	V034-59082	1
	Port plate - rear C.C.W.	V034-59083	V034-59083	V034-59083	
9b	Pin vane holdout	V034-59161	V034-59161	V034-70259	12
9c	Vane	V034-59162	V034-59162	V034-59162	12
9d	Cam ring - 042	V034-66899	V034-66899	V034-66899	1
	Cam ring - 045	V034-59164	V034-59164	V034-59164	
	Cam ring - 050	V034-66744	V034-66744	V034-66744	
	Cam ring - 052	V034-59165	V034-59165	V034-59165	
	Cam ring - 062	V034-59166	V034-59166	V034-59166	

Item pos.	Description	Part No.			Qty
		VT6ED (Standard)	VT6ED (Bi-dir plates) (only for P2)	VT6EDM/VT6EDP -0**-B**	
	Cam ring - 066	V034-59167	V034-59167	V034-59167	
	Cam ring - 072	V034-66736	V034-66736	V034-66736	
	Cam ring - 085				
9e	Dowel pin	V324-22016	V324-22016	V324-22016	2
9f	Back-up ring	V618-15018	V618-15018	V618-15018	1
9g	Port plate - pressure C.W.	V034-59159	V034-59159	V034-59159	1
	Port plate - pressure C.C.W.	V034-59160	V034-59160	V034-59160	
9h	Sq. section seal	V691-10237	V691-10237	V691-10237	1
9j	Sq. section seal	V691-10253	V691-10253	V691-10253	1
9k	Rotor-insert ass'y	VS24-10185	VS24-10185	VS24-30019	1
9m	Screw	V310-10340	V310-10340	V310-10340	2
9n	Lockwasher internal tooth	V348-10010	V348-10010	V348-10010	2
9p	Dowel pin	V323-82014	V323-82014	V323-82014	1
9r	Sq. section seal	V671-10259	V671-10259	V671-10259	1
10	Cartridge assembly *14 C.W. (P2)	VS24-40795	C-S14-71672	VS24-40797	1
	Cartridge assembly *14 C.C.W. (P2)	VS24-40796	C-S14-71673	VS24-40798	
	Cartridge assembly *20 C.W. (P2)	VS24-26492	C-S14-71674	VS24-40330	
	Cartridge assembly *20 C.C.W. (P2)	VS24-26493	C-S14-71675	VS24-40331	
	Cartridge assembly *24 C.W. (P2)	VS14-25893	C-S14-71676	VS24-40332	
	Cartridge assembly *24 C.C.W. (P2)	VS24-25894	C-S14-71677	VS24-40333	
	Cartridge assembly *28 C.W. (P2)	VS24-10861	VS24-10220	VS24-40334	
	Cartridge assembly *28 C.C.W. (P2)	VS24-10862	VS24-10221	VS24-40335	
	Cartridge assembly *31 C.W. (P2)	VS24-10863	VS24-10222	VS24-40336	
	Cartridge assembly *31 C.C.W. (P2)	VS24-10864	VS24-10223	VS24-40337	
	Cartridge assembly *35 C.W. (P2)	VS24-10865	VS24-10224	VS24-40338	
	Cartridge assembly *35 C.C.W. (P2)	VS24-10866	VS24-10225	VS24-40339	
	Cartridge assembly *38 C.W. (P2)	VS24-10867	VS24-10226	VS24-40340	
	Cartridge assembly *38 C.C.W. (P2)	VS24-10868	VS24-10227	VS24-40341	
	Cartridge assembly *42 C.W. (P2)	VS24-10869	VS24-10228	VS24-40342	
	Cartridge assembly *42 C.C.W. (P2)	VS24-10870	VS24-10229	VS24-40343	
	Cartridge assembly *45 C.W. (P2)	VS24-10871	VS24-10230	VS24-40344	
	Cartridge assembly *45 C.C.W. (P2)	VS24-10872	VS24-10231	VS24-40345	
	Cartridge assembly *50 C.W. (P2)	VS24-40387	C-S14-71680	VS24-40346	
	Cartridge assembly *50 C.C.W. (P2)	VS24-40388	C-S14-71681	VS24-40347	
10a	Port plate - rear C.W.	V034-59812			1
	Port plate - rear C.C.W.	V034-59813			
	Port plate - rear Bi-dir		V034-59119	V034-59119	
10b	Pin vane holdout	V034-59130	V034-59130	V034-24984	10
10c	Vane	V034-53588	V034-53588	V034-53588	10
10d	Cam ring - 014	V034-66708	V034-66708	V034-66708	1
	Cam ring - 020	V034-66596	V034-66596	V034-66596	
	Cam ring - 024	V034-59294	V034-59294	V034-59294	
	Cam ring - 028	V034-59133	V034-59133	V034-59133	
	Cam ring - 031	V034-59135	V034-59135	V034-59135	
	Cam ring - 035	V034-59137	V034-59137	V034-59137	
	Cam ring - 038	V034-59139	V034-59139	V034-59139	
	Cam ring - 042	V034-59132	V034-59132	V034-59132	
	Cam ring - 045	V034-59131	V034-59131	V034-59131	
	Cam ring - 050	V034-66737	V034-66737	V034-66737	
10e	Dowel pin	V324-21612	V324-21612	V324-21612	2
10f	Back-up ring	V618-15017	V618-15017	V618-15017	1

Item pos.	Description	Part No.			Qty
		VT6ED (Standard)	VT6ED (Bi-dir plates) (only for P2)	VT6EDM VT6EDP -0**-B**	
10g	Port plate - pressure C.W.	V034-59809			1
	Port plate - pressure C.C.W.	V034-59808			
	Port plate - pressure		V034-59057	V034-59057	
10h	Sq. section seal	V691-10232	V691-10232	V691-10232	1
10j	Sq. section seal	V691-10244	V691-10244	V691-10244	1
10k	Rotor-insert ass'y	VS24-10121	VS24-10121	VS24-30018	1
10m	Screw	V317-10320	V317-10320	V317-10320	2
10n	Lockwasher internal tooth	V348-10010	V348-10010	V348-10010	2
10q	Dowel pin	V323-82004	V323-82004	V323-82004	1
10p	Bush	V034-59901	V034-59901	V034-59901	1
10r	Sq. section seal	V671-10159	V671-10159	V671-10159	1
7	Seal kit (S1 - 0,7 bar)	VS24-10219	VS24-10219	VS24-10219	1
9f,9h	Seal kit (S4 - 7 bar)	VS24-10219-4	VS24-10219-4	VS24-10219-4	
9j,9r	Seal kit (S5 - 7 bar)	VS24-10219-5	VS24-102195	VS24-10219-5	
10f,10h 10j,10r	Seal kit (S1 - 0,7 bar) (VT6EDP)			VS24-40348	
9a	Port plate - rear ass'y C.W. (P1)	VS24-10214	VS24-10214	VS24-10214	1
	Port plate - rear ass'y C.C.W. (P1)	VS24-10215	VS24-10215	VS24-10215	
10a	Port plate - rear and bush ass'y C.W. (P2)	VS24-10833			1
10p	Port plate - rear and bush ass'y C.C.W. (P2)	VS24-10834			
	Port plate - rear and bush ass'y Bi-dir (P2)		VS24-10216	VS24-10216	

* 0 - Standard
 B - Bi-directional plates/Mobile (only for 'D' cartridge)
 R - Mobile-Spring assisted (on request)

To change porting position, follow the steps below:

- Secure pump and remove 4 bolts from mounting flange. Move the mounting flange 1 to 2 mm away from housing. Insert one bolt halfway to mounting flange. Install a wrench between the shaft and bolt and turn in the desired way, so that the required position of P1 port with respect to Suction is obtained. Reinstall the bolts and tighten to corresponding mounting torque as provided on page 2.
- Follow similar procedure for changing P2 position. Use wrench between two bolts placed diagonally opposite.

Instruction: Do not remove mounting flange/end cap completely from the housing but only just 1 to 2 mm to avoid the cartridge pin to move out from the housing dowel pin hole. Make sure no piece of paint enters into the gap to avoid leakage. If it is difficult to turn mounting flange/end cap put some hydraulic oil into the pressure port to lubricate the pressure port seals.

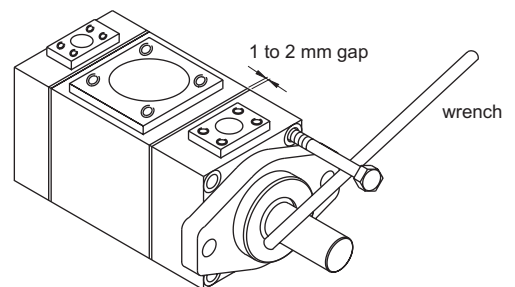

MODEL CODE

VT6ED * * - *66 - *35 - 1 R 00 - C 1 - *

Series

- * **M** = Mobile
- * **P** = Mobile with double shaft seal (* omit for Industrial)

Y = Metric port connection, omit for UNC

Cam ring	Displacement	Cam ring	Displacement
	in ³ /rev (cm ³ /rev)		in ³ /rev (cm ³ /rev)
042/R42	= 8.07 (132.30)	062/R62	= 12.00 (196.70)
045/R45	= 8.70 (142.40)	066/R66	= 13.00 (213.30)
050/R50	= 9.67 (158.50)	072/R72	= 13.86 (227.10)
052/R52	= 10.00 (164.80)	085/R85	= 16.40 (269.80)

Select 'R **' for Mobile-spring assisted

Cam ring	Displacement	Cam ring	Displacement
	In ³ /rev (cm ³ /rev)		In ³ /rev (cm ³ /rev)
014/B14/R14	= 2.90 (47.60)	038/B38/R38	= 7.30 (120.30)
020/B20/R20	= 4.00 (66.00)	042/B42/R42	= 8.30 (136.00)
024/B24/R24	= 4.85 (79.50)	045/B45/R45	= 8.90 (145.70)
028/B28/R28	= 5.00 (89.70)	050/B50/R50	= 9.64 (158.00)
031/B31/R31	= 6.00 (98.30)		
035/B35/R35	= 6.80 (111.00)		

Select 'B ***' for Mobile and Bi-directional

Select 'R **' for Mobile-spring assisted

Type of Shaft

VT6ED	1 = Keyed (SAE -CC)
	2 = Keyed (no SAE)
	3 = Splined (SAE -C)
	4 = Splined (SAE-CC)

Type of Shaft

VT6EDM	1 = Keyed (SAE -CC)
	2 = Keyed (no SAE)
	3 = Splined (SAE -C)
	4 = Splined (no SAE)
	T = Splined (SAE J718c)

Type of Shaft

VT6EDP	3 = Splined (no SAE)
---------------	-----------------------------

Modification

Seal class

- 1** = S1 - BUNAN
- 4** = S4 - EPDM
- 5** = S5 - VITON

Design letter

- B** = Industrial
- C** = Mobile

Porting combination : (00 = Standard)

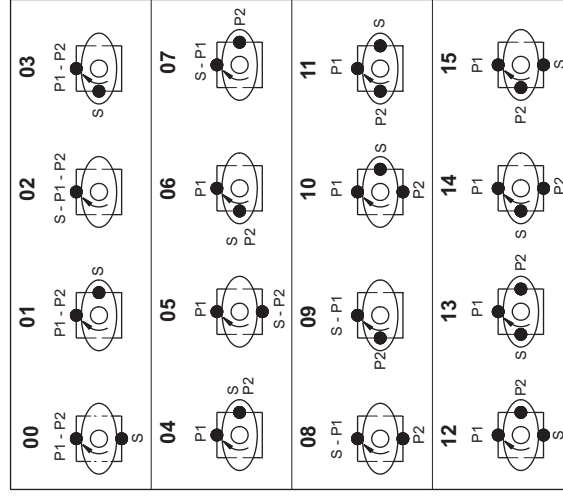

P - Pressure
S - Suction

Direction of rotation

- R** = Clockwise
- L** = Counter - clockwise

Veljan Hydrair Private Limited, Balanagar, Hyderabad - 500 037, INDIA . Phone : +91-40-3772794,95 Fax : +91-40-3773963, www.veljan.com